

REVISION

REV	DATE	DESCRIPTION
△	9/03/20	INITIAL

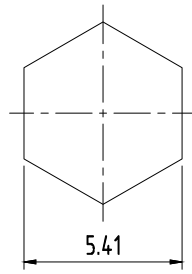

RECOMMENDED
USE CRIMP TOOL DIE 0.213"

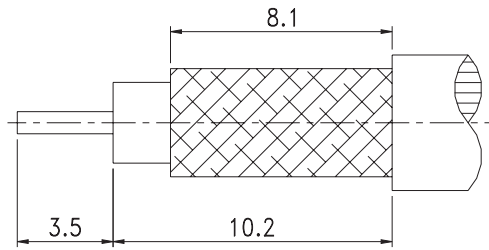

RECOMMENDED
CABLE STRIPPING DIM S

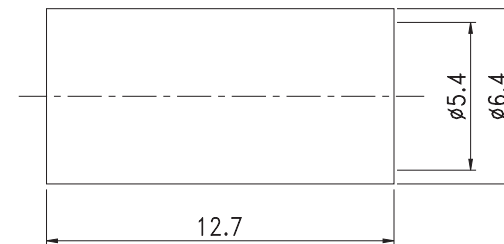
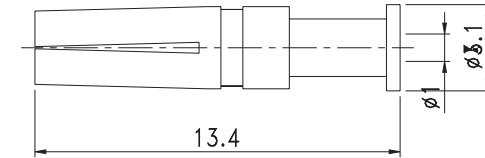
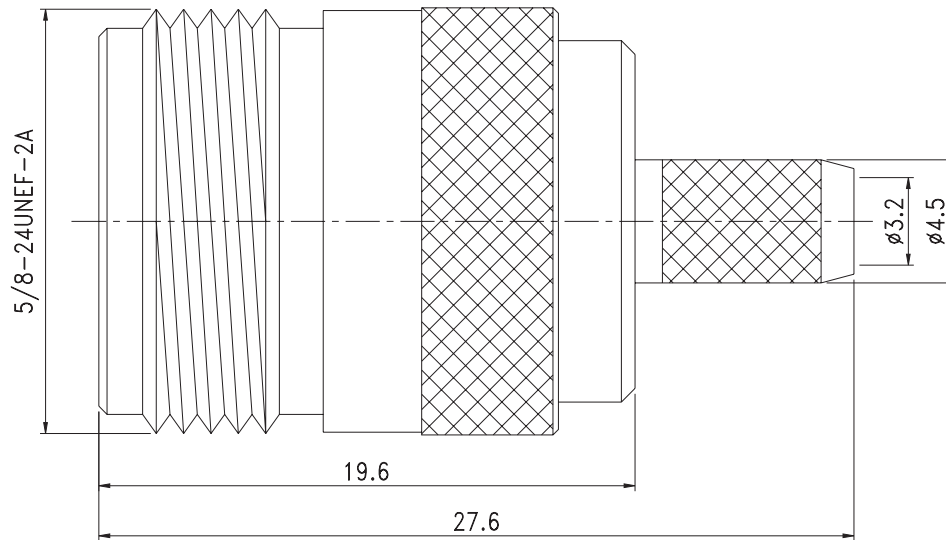

5.	Ferrule	Brass	1	Nickel
4.	Insulation	Teflon	1	None
3.	Pin	Brass	1	Gold
2.	Barrel	Brass	1	Nickel
1.	Body	Brass	1	Nickel
NO.	DESCRIPTION	MATERIAL	Q'TY	FINISH

UNITS	SCALE	SIZE	TOLERANCE	DRAWN BY:	CHECKED BY:	CAD FILE
[in] mm	NTS	A	.X +/- 0.2 .XX +/- 0.1 .XXX +/- 0.05 ANGLE +/- 0.5			11-14F-2-TGN
SHEET 1 OF 1			PROPRIETARY AND CONFIDENTIAL THE INFORMATION IN THIS DRAWING IS THE SOLE PROPERTY OF TCC INDUSTRIES INC. ANY REPRODUCTION IN PART OR AS A WHOLE WITHOUT THE WRITTEN PERMISSION OF TCC INDUSTRIES INC. IS PROHIBITED.			

DESCRIPTION
N-Type, Jack/Female Cable Crimp, Straight for TCC Cable Group F



TCC INDUSTRIES INC.

7050 Village Drive unit E, Buena Park, CA 90621-2282
Tel. 714.523.8885 - FAX. 714.562.0888
E-Mail: info@tccinc.com Website: www.tccinc.com